



# WASTE BALING PRESSES

Baler PBS200

## Baler ARTechnic PBs200



### Advantages of the machine:

- **The moving of the pressing plate is kept extremely rigid and straight.** The hydraulic cylinder does not take the bending forces from the pressing plate, which could lead to its damage. These forces are taken over by special plastic guides which are tailored to the corners of the chamber ironing. The guides are made from specially chosen plastic, which is characterized by very high resistance to abrasion. Therefore, these elements are extremely durable. This avoids the need to control the tilt of the pressing plate. Because of all this you can easily exploit our machines, even for very demanding materials, without worrying of an improperly use of the machine.
- **The steel construction** of our machines is designed to withstand loads far in excess of the rated load for the different models (this is why our machines have a generally bigger own mass compared to the competition)
- **A system to prevent the decompressing of material** after subsequent cycles of work.

- **Possibility to bind the packages (bales) with all commonly used materials** like a polyester tape, twine or steel wire;
- **The possibility of producing specified machines** concerning the customer's request e.g. changes in the stroke of the pressing plate, changes in the loading hole, changes in the size of the bale, etc.
- **Possibility to choose the version of the controller** and to choose additional options, depending on individual needs
- **Unmanned and durable** hydraulic system
- **No hidden costs of operating the machine**

### Technical specification

Number of chambers:	single	Loading:	frontal
Charging hole:	1080 x 550 mm	Bale tying:	manual
Max. pressure:	200kN (20 tons)	Bale launch:	automatic
Unit pressure:	2,6 kg/cm <sup>2</sup>	Supply:	400/50 [V/Hz]
Bale dimensions:	1100 x 700 x 800	Engine power:	4 kW
Bale weight:	app. 150 – 200 kg	Work cycle:	ca. 30 seconds
Productivity:	app. 2 – 3 bale/h	Weight:	1400 kg

### Dimension

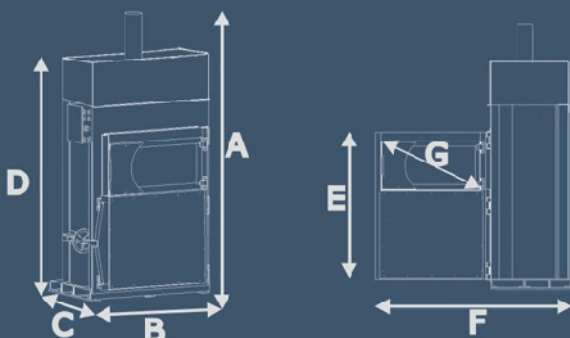

LEGEND		[mm]
<b>A</b>	height	2650
<b>B</b>	width	1500
<b>C</b>	depth	1100
<b>D</b>	transport height	2150
<b>E</b>	door height	1400
<b>F</b>	depth with open door	1985
<b>G</b>	filling inlet	1080 x 550

s-line series

**Available steering types**

**Steering s (STANDARD)**

**Steering x (EXTRA)**

**Features**

- Controller PLC
- Automatic digital steering of the work cycle
- Finished-bale signal
- Two-step bale height regulation

- Controller PLC
- Automatic digital steering of the work cycle
- Finished-bale signal
- LCD display
- Stepless maximum pressure regulation with 1 ton progression
- Stepless bale height regulation with 2 cm progression
- Daily/weekly/monthly statistics – the readout of the number of finished bales with their weight estimation
- Different programs for different materials
- Possibility of regulating the length of time for which the pressing plate stays in the lower position

**Control Panel**

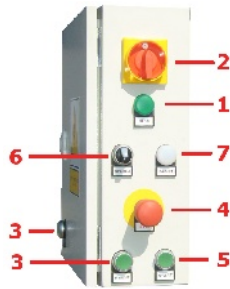

1. The green light "POWER" indicates a connection of the bale to power and that the main switch is turned ON
2. Main switch with the possibility to lock in position "0" (prevents from an use of the machine by unauthorized persons)
3. Buttons "THROW-OFF". Two-handed operation – controller for the bale ejector
4. Emergency "STOP" switch
5. Button "START" - starts the pressing process
6. Switch for (two-stage) bale height regulation
7. The white light "PACKET" indicates that the press has achieved the maximum filling

1. Main switch with the possibility to lock in position "0" (prevents from an use of the machine by unauthorized persons)
2. The white light "PACKET" indicates that the press has achieved the maximum filling
3. LCD and control panel
4. The green light "POWER" indicates a connection of the bale to power and that the main switch is turned ON
5. Emergency "STOP" switch
6. Button "START" - starts the pressing process
7. Buttons "THROW-OFF". Two-handed operation – controller for the bale ejector

**Gallery**



**Contact**

**Headquarter:** ARTechnic, ul. Gen. St. Maczka 9, 43-300 Bielsko-Biała, Poland

**Phones:** **tel.:** +48 (33) 488 31 39; **tel.:** +48 (33) 488 12 87; **tel./fax:** +48 (33) 816 01 69; **mobile:** +48 509 033 132; **mobile:** +48 501 330 786; **mobile:** +48 509 033 134; **service mobile:** +48 509 451 124;

**E-mail Web site** **E-mail:** [biuro@artehnic.pl](mailto:biuro@artehnic.pl), [rluba@artehnic.pl](mailto:rluba@artehnic.pl), [bartekb@artehnic.pl](mailto:bartekb@artehnic.pl), [tomek@artehnic.pl](mailto:tomek@artehnic.pl), [jskrudlik@artehnic.pl](mailto:jskrudlik@artehnic.pl), **WWW:** [www.artehnic.pl](http://www.artehnic.pl) [www.belownicezywane.pl](http://www.belownicezywane.pl)