



Baler ARTechnic PBs70



Advantages of the machine:

- **The moving of the pressing plate is kept extremely rigid and straight.**
The hydraulic cylinder does not take the bending forces from the pressing plate, which could lead to its damage. These forces are taken over by special plastic guides which are tailored to the corners of the chamber ironing. The guides are made from specially chosen plastic, which is characterized by very high resistance to abrasion. Therefore, these elements are extremely durable. This avoids the need to control the tilt of the pressing plate. Because of all this you can easily exploit our machines, even for very demanding materials, without worrying of an improperly use of the machine.
- **The steel construction** of our machines is designed to withstand loads far in excess of the rated load for the different models (this is why our machines have a generally bigger own mass compared to the competition)
- **A system to prevent the decompressing of material** after subsequent cycles of work.
- **Possibility to bind the packages (bales) with all commonly used materials** like a polyester tape, twine or steel wire;
- **The possibility of producing specified machines** concerning the customer's request e.g. changes in the stroke of the pressing plate, changes in the loading hole, changes in the size of the bale, etc.

- **Possibility to choose the version of the controller** and to choose additional options, depending on individual needs
- **Unmanned and durable** hydraulic system
- **No hidden costs of operating the machine**

Technical specification

Number of chambers:	single	Loading:	frontal
Charging hole:	700 x 500 mm	Bale tying:	manual
Max. pressure:	70kN (7 tons)	Bale launch:	automatic
Unit pressure:	2 kg/cm ²	Supply:	400/50 [V/Hz]
Bale dimensions:	700 x 500 x 600	Engine power:	2,2 kW
Bale weight:	app. 30 – 80 kg	Work cycle:	ca. 30 seconds
Productivity:	app. 3 – 4 bale/h	Weight:	750 kg

Dimension

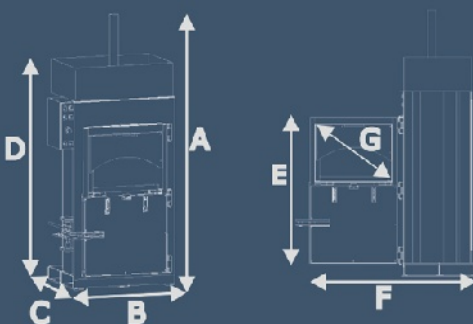

LEGEND		[mm]
A	height	2320
B	width	1080
C	depth	740
D	transport height	1905
E	door height	1225
F	depth with open door	1680
G	filling inlet	700 x 500

Available steering types

Steering b (BASIC)	Steering p (PLUS)
Features	
<ul style="list-style-type: none"> ● Controller PLC ● Automatic digital steering of the work cycle 	<ul style="list-style-type: none"> ● Controller PLC ● Automatic digital steering of the work cycle ● Finished-bale signal

Control Panel



1. The green light "POWER" indicates a connection of the bale to power and that the main switch is turned ON
2. Main switch with the possibility to lock in position "0" (prevents from an use of the machine by unauthorized persons)
3. Buttons "THROW-OFF". Two-handed operation – controller for the bale ejector
4. Emergency "STOP" switch
5. Button "START" starts the pressing process

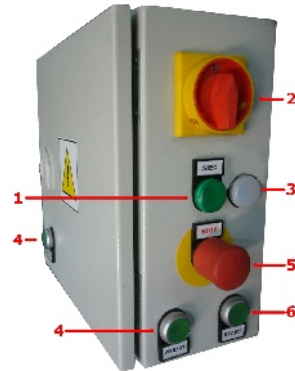

1. The green light "POWER" indicates a connection of the bale to power and that the main switch is turned ON
2. Main switch with the possibility to lock in position "0" (prevents from an use of the machine by unauthorized persons)
3. The white light "PACKET" indicates that the press has achieved the maximum filling
4. Buttons "THROW-OFF". Two-handed operation – controller for the bale ejector
5. Emergency "STOP" switch
6. Button "START" - starts the pressing process

Gallery



Contact

Headquarter	Phones	E-mail and Web Site
ARTechnic ul. Gen. St. Maczka 9 43-300 Bielsko-Biała Poland	tel. +48 (33) 488 31 39 tel. +48 (33) 488 12 87 tel./fax +48 (33) 816 01 69 mobile +48 509 033 132 mobile +48 501 330 786 mobile +48 509 033 134 Service mobile +48 509 451 124	biuro@arotechnic.pl rluba@arotechnic.pl bartekb@arotechnic.pl tomek@arotechnic.pl jskrudlik@arotechnic.pl www.arotechnic.pl www.belowniceuzywane.pl